

# EM24 W1



Energy analyzer for 1-phase and 3-phase systems, wireless M-Bus communication



## Benefits

- **Time saving set-up**, by frontal joystick and selector.
- **Error-proof installation**, by self-power supply and phase sequence detection.
- **Easy variable scrolling**, by means of the front joystick.
- **Flexible installation**, by means of the direct connection up to 65 A or the connection of 5 A current transformers.
- **Accurate measurement**. It is compliant with the international accuracy standard IEC/EN62053-21, and the IEC/EN61557-12 performance requirements (active power and active energy).
- **Legal metrology**, guaranteed by the MID approval
- **Wireless communication**, wireless M-Bus version allows remote data collection when cabling is not possible due to cost or installation requirements.
- **Easy commissioning** of wireless communication thanks to the test function of the joystick and to transmission counter for diagnostics.

## Description

Three-phase energy analyzer for DIN-rail mounting with configuration joystick, frontal selector and LCD display. Direct connection up to 65A or via current and voltage transformers. The wireless M-Bus communication is the perfect solution when cabling is not possible.

## Applications

EM24 is the perfect solution in any application, specially in building and industrial automation where energy and main electrical variables monitoring is required.

EM24 is particularly suited for:

- energy efficiency monitoring
- cost allocation
- fiscal/legal sub-billing, where the wireless M-Bus version is the best choice for quick and easy installation without cables. Encryption ensures data security and safeguards confidentiality.

## Main functions

- Measurement of energy consumption and main electrical variables of single-phase, two-phase or three-phase loads.
- Display of single phase measurements and total measurements.
- Easy connection function.
- Transmission of data via wireless M-Bus (868 MHz for the European market).
- Two wireless M-Bus versions: a compact model with internal antenna and a SMA connector model with external antenna (in case of metallic switchboard).

## Main features

- TRMS measurements of distorted sine waves (voltages/currents)
- Data encryption (a unique key will be provided for any device in a sealed envelope included in the instrument box)
- Compliant with IEC/EN61557-12 performance requirements (active power and active energy)

## Structure

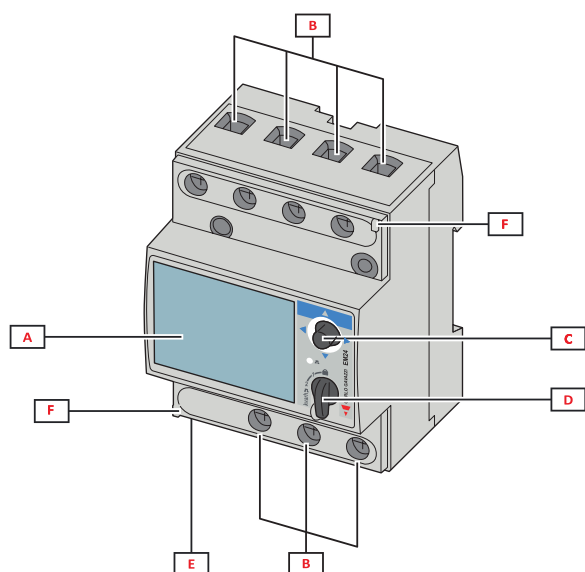

Fig. 1 Direct connection

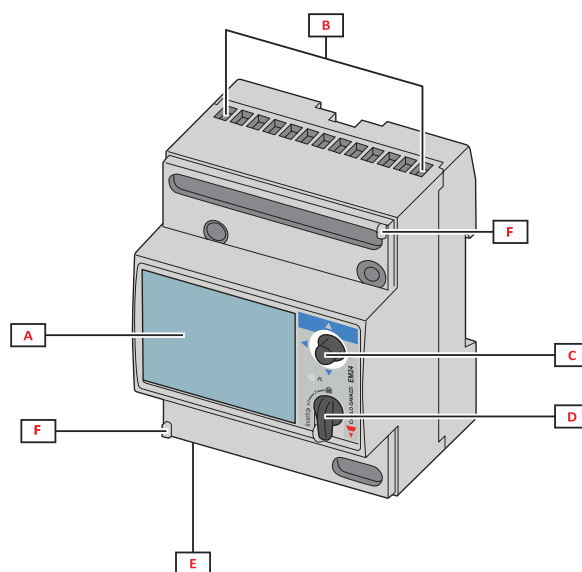

Fig. 2 CT connection

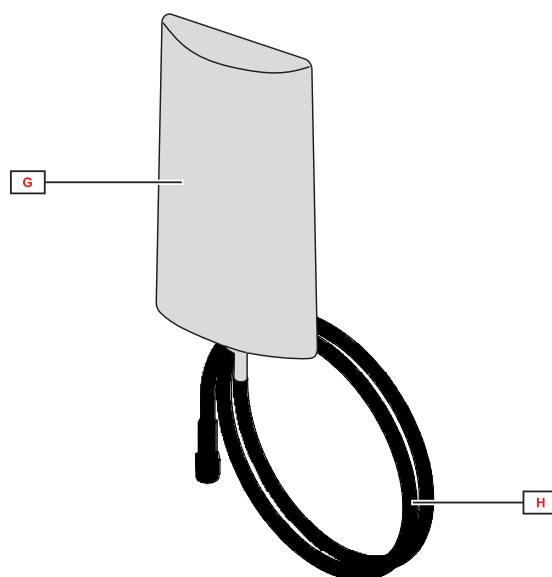

Fig. 3 External antenna (only for EM24DINAV...W1E...)



---

Area	Description
A	LCD display
B	Voltage/current connections
C	Joystick
D	Selector with pin for MID seal (programming block)
E	Inputs/outputs or communication port
F	Pins for MID seal (protection covers included)
G	External antenna for wireless M-Bus communication
H	SMA connector cable (2 m)

# Features

## General

<b>Protection degree</b>	Front: IP50. Terminals: IP20
<b>Terminals</b>	Screw terminals AV2: Max.: 16 mm <sup>2</sup> , min.: 2.5 mm <sup>2</sup> (by cable lug) AV5: Max.: 1.5 mm <sup>2</sup>
<b>Overvoltage category</b>	Cat. III
<b>Utilisation category</b>	UC2
<b>Pollution degree</b>	2
<b>Noise rejection (CMRR)</b>	100 dB, from 42 to 62 Hz
<b>Mounting</b>	DIN rail
<b>Weight</b>	400 g (packaging included) 800 g with external antenna (packaging included)

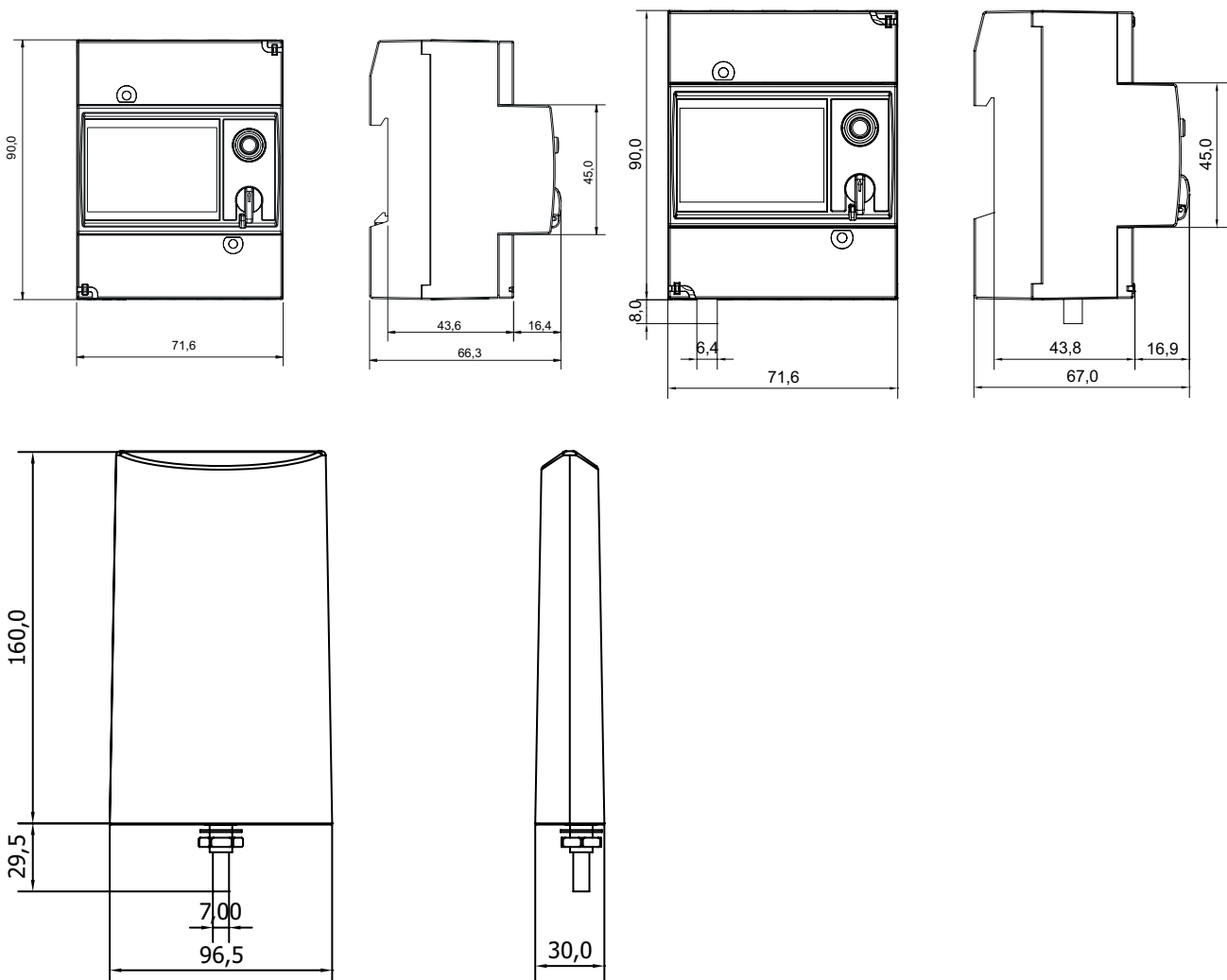



## Environmental specifications

<b>Operating temperature</b>	From -25 to +55 °C/from -13 to +131 °F
<b>Storage temperature</b>	From -30 to +70 °C/from -22 to +158 °F

NOTE: R.H. < 90 % non-condensing @ 40 °C / 104 °F.

## Compatibility and conformity

<b>Directives</b>	2011/65/EU (RoHs), 2014/53/EU (RED)
<b>Standards</b>	Electromagnetic compatibility (EMC) - emissions and immunity: EN 62052-11 Electrical safety: EN 61010-1, EN 50470-1 (MID), UL 61010-1 Accuracy: EN 62053-21, EN 62053-23, EN 50470-3 (MID), IEC/EN61557-12 (active power and active energy, MID models only)
<b>Approvals</b>	  MID (PF only)

## Electrical specifications

Voltage - MID models		
Voltage inputs	AV2	AV5
<b>Voltage connection</b>	Direct	
<b>Rated voltage L-N (from Un min to Un max)</b>	133 to 230 V	230 V
<b>Rated voltage L-L (from Un min to Un max)</b>	230 to 400 V	400 V
<b>Voltage tolerance (*)</b>	-20%, +15%	
<b>Overload (**)</b>	Continuous: 1.15 Un max	
<b>Input impedance</b>	Refer to "Power supply"	
<b>Frequency</b>	50 Hz	

Voltage - Non MID models (according to IEC 62052-11)		
Voltage inputs	AV2	AV5
<b>Voltage connection</b>		
<b>Rated voltage L-N (from Un min to Un max)</b>	120 to 277 V	120 to 277 V
<b>Rated voltage L-L (from Un min to Un max)</b>	208 to 480 V	208 to 480 V
<b>Voltage tolerance (*)</b>	-20%, +15%	
<b>Overload (**)</b>	Continuous: 1.15 (Un max)	Continuous: 1.2 (Un max)
<b>Input impedance</b>	Refer to "Power supply"	>1600 kΩ
<b>Frequency</b>	50/60 Hz	

(\*) reference range for stated accuracy

(\*\*) max reference for no instrument damage

Current		
Current inputs	AV2	AV5
Current connection	Direct	Via CT
Rated current (In)	-	5 A
Base current (Ib)	10 A	-
Minimum current (Imin)	0.5 A	0.05 A
Maximum current (Imax)	65 A	10 A
Start-up current (Ist)	0.04 A	0.01 A
Overload	Continuous: 65 A @50 Hz For 10 ms: 1950 A @50 Hz	Continuous: 10 A @50 Hz For 500 ms: 200 A @ 50 Hz
Short circuit withstand	For 10 ms: 4500 A according to IEC 62052-31:2015	-
Input impedance	< 1.1 VA	< 0.6 VA
Crest factor	4 (Imax peak 92 A)	3 (Imax peak 15 A)

Maximum CTxVT ratio		
Current inputs	AV2	AV5
Non-MID models except E1	-	4629
Non-MID models: E1, W1	-	6975
MID models except E1	-	3150
MID models: E1, W1	-	2615

### Power supply

Non MID models		
	AV2	AV5
Type	Self power supply	Self power supply
Consumption	2.7VA /1.8W	

MID models		
	AV2	AV5
Type	Self power supply	
Consumption	W1: 2.7VA /1.8W	

### Measurements

Method	TRMS measurements of distorted waveforms
Sampling	1600 samples/s @50 Hz 1900 samples/s @60 Hz

### Available measurements

Active energy	Unit	System	Phase	Note
Imported (+) Total	kWh+	•	•	
Imported (+) partial	kWh+	•	-	
Exported (-) Total	kWh-	•	-	

Reactive energy	Unit	System	Phase
Imported (+) Total	kvarh+	●	-
Imported (+) partial	kvarh+	●	-
Exported (-) Total	kvarh-	●	-
Imported (+) by tariff	kvarh+	●	-

Electrical variable	Unit	System	Phase
Voltage L-N	V	●	●
Voltage L-L	V	●	●
Current	A	-	●
DMD MAX	A	●	-
Active power	kW	●	●
DMD	kW	●	-
DMD MAX	kW	●	-
Apparent power	kVA	●	●
DMD	kVA	●	-
DMD MAX	kVA	●	-
Reactive power	kvar	●	●
Power factor	PF	●	●
Frequency	Hz	●	-
Run hour meter	h	●	-

### Measurement mode

Depending on the APPLICATION setting, a different selection of variables is available on the display (see manual) and the energy calculation is worked out as follows:

- Standard: both kWh+ and kWh- are available;
- EC: easy connection function, the power is always integrated (both in case of positive and negative power).

In MID analyzers the calculation depends on the model:

- PFA: Easy connection, the total energy totalizer (kWh+) is certified according to MID;
- PFB: only the total positive totalizer (kWh+) is certified according to MID. The negative energy totalizer is available but not certified according to MID.

### Energy metering

For every measuring interval time, the energies of the single phases are summed; according to the sign of the result, the positive (kWh+) or negative totalizer (kWh-) is increased.

Example:

P L1= +2 kW, P L2= +2 kW, P L3= -3 kW

Integration time = 1 hour

+kWh=(+2+2-3)x1h=(+1)x1h=1 kWh

-kWh=0 kWh

### Measurement accuracy

Current	AV2	AV5
From 0.5 A to 2 A	$\pm(0.5\% \text{ rdg} + 3\text{dgt})$	-
From 2 A to 65 A	$\pm(0.5\% \text{ rdg} + 1\text{dgt})$	-
From 0.05 A to 1 A	-	$\pm(0.5\% \text{ rdg} + 3\text{dgt})$
From 1 A to 10 A	-	$\pm(0.5\% \text{ rdg} + 1\text{dgt})$



<b>Phase-phase voltage</b>	AV2	AV5
<b>In the range Un</b>	$\pm(1\% \text{ rdg} + 1\text{dgt})$	
<b>Phase-neutral voltage</b>	AV2	AV5
<b>In the range Un</b>	$\pm(0.5\% \text{ rdg} + 1\text{dgt})$	
<b>Active and apparent power</b>	AV2	AV5
<b>From 1.0 A to 65.0 A (PF=0.5L, 1, 0.8C)</b>	$\pm(1\% \text{ rdg} + 1\text{dgt})$	-
<b>From 0.5 A to 1.0 A (PF=1)</b>	$\pm(1.5\% \text{ rdg} + 1\text{dgt})$	-
<b>From 0.25 A to 10 A (PF=0.5L, 1, 0.8C)</b>	-	$\pm(1\% \text{ rdg} + 1\text{dgt})$
<b>From 0.05 A to 0.25 A (PF=1)</b>	-	$\pm(1.5\% \text{ rdg} + 1\text{dgt})$
<b>Reactive power</b>	AV2	AV5
<b>From 1.0 A to 2.0 A (sin<math>\phi</math>=0.5L, 0.5C)</b>	$\pm(2.5\% \text{ rdg} + 1 \text{ dgt})$	-
<b>From 0.5 A to 1.0 A (sin<math>\phi</math>=1)</b>		
<b>From 2.0 A to 65.0 A (sin<math>\phi</math>=0.5L, 0.5C)</b>	$\pm(2\% \text{ rdg} + 1 \text{ dgt})$	-
<b>From 1.0 A to 65.0 A (sin<math>\phi</math>=1)</b>		
<b>From 0.25 A to 0.5 A (sin<math>\phi</math>=0.5L, 0.5C)</b>	-	$\pm(2.5\% \text{ rdg} + 1 \text{ dgt})$
<b>From 0.1 A to 0.25 A (sin<math>\phi</math>=1)</b>		
<b>From 0.5 A to 10 A (sin<math>\phi</math>=0.5L, 0.5C)</b>	-	$\pm(2\% \text{ rdg} + 1 \text{ dgt})$
<b>From 0.25 A to 10 A (sin<math>\phi</math>=1)</b>		
<b>Active energy</b>	Class 1 (EN62053-21) Class B (EN50470-3) (MID)	
<b>Reactive energy</b>	Class 2 (EN62053-23)	
<b>Frequency</b>		
<b>From 45 to 65 Hz</b>	$\pm 0.1 \text{ Hz}$	

<b>Measurement accuracy according to IEC/EN61557-12 (MID models)</b>	
<b>Active power</b>	Performance class 1
<b>Active energy</b>	Performance class 2

## ▶ Display

<b>Type</b>	LCD
<b>Refresh time</b>	< 750 ms
<b>Description</b>	3 rows: 1 <sup>st</sup> : 8 digits (7 mm) 2 <sup>nd</sup> : 4 digits (7 mm) 3 <sup>rd</sup> : 4 digits (7 mm)
<b>Variable readout</b>	Instantaneous: 4 digits, min: 0.000, max: 9999 Energy: 8 digits (imported), 7 digits (exported), min: 0.00, max: 99 999 999



 LED

Model	CT*VT	Weight (kWh per pulse)
AV5	$\leq 7$	0.001
	$> 7 \leq 70.0$	0.01
	$> 70 \leq 700.0$	0.1
	$> 700$	1
AV2	N/A	0.001

## Communication ports

### Wireless M-Bus (W1)

<b>Protocols</b>	Wireless M-Bus according to EN13757-3, EN13757-4 . OMS certified (*).
<b>Frame format</b>	A
<b>Frequency</b>	868 MHz
<b>Frame type</b>	Selectable among the followin options: -1: kWh+ -2: kWh+, kvarh+, kvarh-, kW+ -3: kWh+, kvarh+, kvarh-, kW+, kvar+, kvar-, current by phase, voltage by phase, frequency -4: kWh+, kWh-, kvarh+, kvarh-, kW+, kW-, kvar+, kvar-
<b>Mode</b>	T1 or C1
<b>Encryption</b>	No encryption, ENC-Mode 5 (security profile A) or ENC-Mode 7 (security profile B)
<b>Transmission interval</b>	Selectable from 10 s to 60 min
<b>Configuration parameters</b>	Frame type Transmission mode Communication interval Encryption enabling
<b>Configuration mode</b>	Via joystick

Note (\*): OMS certification is valid with the following settings:

- Frame type: 2 or 3
- Communication interval: 30 s, 1 m or 5 m
- Encryption enabled (security profile A or B)

## Connection Diagrams

### Three-phase with neutral (4-wire)

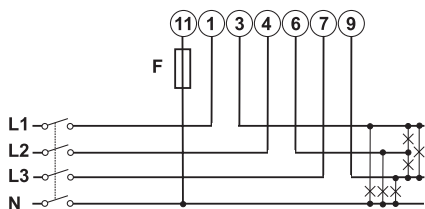

Fig. 4 AV2

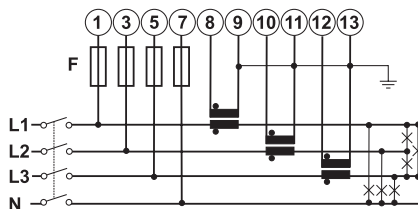

Fig. 5 AV5

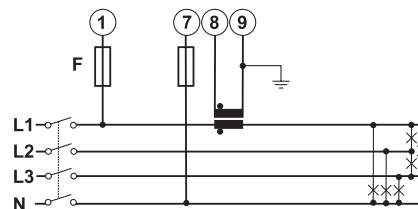

Fig. 6 AV5 balanced load

### Three-phase without neutral (3-wire)

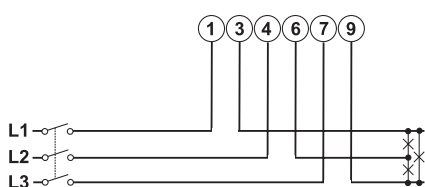

Fig. 7 AV2

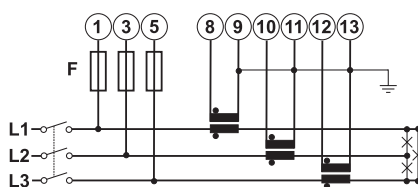

Fig. 8 AV5

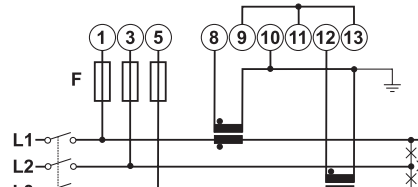

Fig. 9 AV5

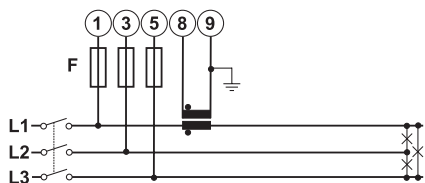

Fig. 10 AV5 balanced load

### Single-phase (2-wire)

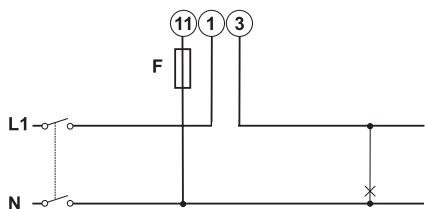

Fig. 11 AV2

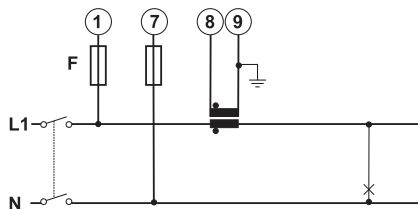

Fig. 12 AV5

Note: F=315 mA

## MID connection diagrams

### Three-phase with neutral (4-wire)

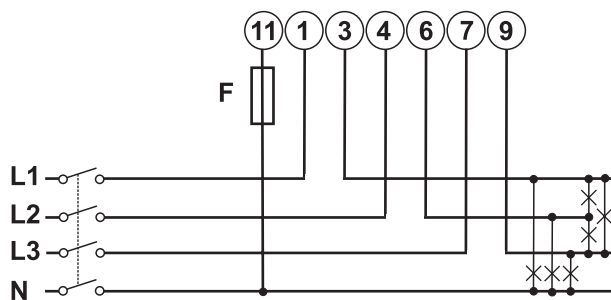

Fig. 13 AV2 3X

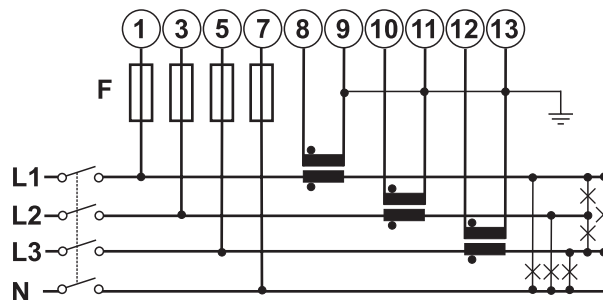

Fig. 14 AV5

### Three-phase without neutral (3-wire) (W1 only)

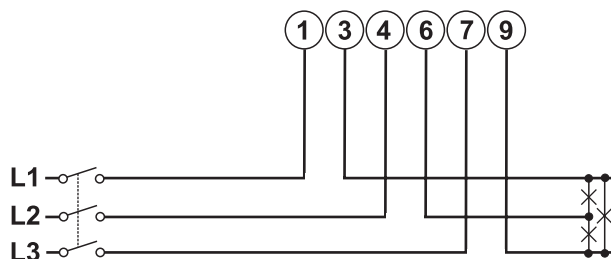

Fig. 15 AV2 3X

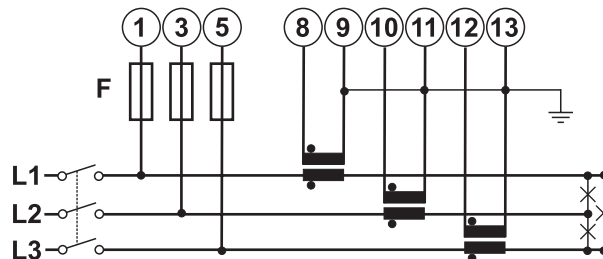

Fig. 16 AV5

### Single-phase (2-wire) (W1 only)

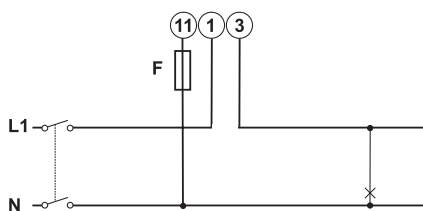

Fig. 17 AV2 1X

Note: F=315 mA

## References

### Order code

Component name/part number	I/O communication	Voltage inputs	Current inputs	Power supply
EM24DIN AV5 3X W1 I X	Wireless M-Bus, internal antenna	From 120 to 277 V L-N From 208 to 480 V L-L	5 (10) A via CT	Self power supply
EM24DIN AV5 3X W1 E X	Wireless M-Bus, external antenna	From 120 to 277 V L-N From 208 to 480 V L-L	5 (10) A via CT	Self power supply
EM24DIN AV2 3X W1 I X	Wireless M-Bus, internal antenna	From 120 to 277 V L-N From 208 to 480 V L-L	10 (65) A	Self power supply
EM24DIN AV2 3X W1 E X	Wireless M-Bus, external antenna	From 120 to 277 V L-N From 208 to 480 V L-L	10 (65) A	Self power supply
EM24DIN AV2 1X W1 I X	Wireless M-Bus, internal antenna, 1-phase	From 120 to 277 V L-N	10 (65) A	Self power supply
EM24DIN AV2 1X W1 E X	Wireless M-Bus, external antenna, 1-phase	From 120 to 277 V L-N	10 (65) A	Self power supply

### MID models

Component name/part number	I/O communication	Voltage inputs	Current inputs	Power supply
EM24DIN AV5 3X W1 I PFA EM24DIN AV5 3X W1 I PFB	Wireless M-Bus, internal antenna	230V L-N 400V L-L	5 (10) A via CT	Self power supply
EM24DIN AV5 3X W1 E PFA EM24DIN AV5 3X W1 E PFB	Wireless M-Bus, external antenna	230V L-N 400V L-L	5 (10) A via CT	Self power supply
EM24DIN AV2 3X W1 I PFA EM24DIN AV2 3X W1 I PFB	Wireless M-Bus, internal antenna	230V L-N 400V L-L	10(65) A	Self power supply
EM24DIN AV2 3X W1 E PFA EM24DIN AV2 3X W1 E PFB	Wireless M-Bus, external antenna	230V L-N 400V L-L	10(65) A	Self power supply
EM24DIN AV2 1X W1 I PFA EM24DIN AV2 1X W1 I PFB	Wireless M-Bus, internal antenna, 1-phase	230V L-N	10(65) A	Self power supply
EM24DIN AV2 1X W1 E PFA EM24DIN AV2 1X W1 E PFB	Wireless M-Bus, external antenna, 1-phase	230V L-N	10(65) A	Self power supply

- PFA: Easy connection, the total energy totalizer (kWh+) is certified according to MID;
- PFB: only the total positive totalizer (kWh+) is certified according to MID. The negative energy totalizer is available but not certified according to MID.

## Further reading

Information	Where to find it
User manual - W1	<a href="http://www.productselection.net/MANUALS/UK/em24_W1_im_use.pdf">www.productselection.net/MANUALS/UK/em24_W1_im_use.pdf</a>
Installation instruction - W1	<a href="http://www.productselection.net/MANUALS/UK/em24_W1_im_inst.pdf">www.productselection.net/MANUALS/UK/em24_W1_im_inst.pdf</a>

## CARLO GAVAZZI compatible components

Purpose	Component name/part number	NOTES
Collect data from wireless M-Bus devices and transmit data via Modbus TCP/IP	SIU-MBM-02	See relevant datasheet

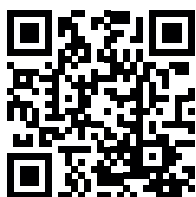

COPYRIGHT ©2021

Content subject to change. Download the PDF: [www.productselection.net](http://www.productselection.net)

### Mindmill AB

Näckroskatan 6  
464 32 Mellerud  
+46 (0)31-758 3000  
[info@mindmill.se](mailto:info@mindmill.se)  
[mindmill.se](http://mindmill.se)



**MINDMILL**